

TRAXON Plus⁺

Vista Plus Midi RGBW



Project: _____

Type: _____



IP66



COAST



DMX/RDM



ANSI 3G



IK08



The Vista Plus Midi RGBW is an AC line powered, high brightness luminaire. Controllable with DMX512, the Vista Plus Midi RGBW is a new member of the Vista Plus family, offering 100W per head with 1-head, 2-head and 3-head options. The daisy chain topology, and direct-wire nature of the fixture via the two integral cable whips allow for simple installation into existing installations and new structures, and is ideal for high-rise and tower illumination. This product is intended for use in high-quality colored light applications.

Features

- DMX / RDM control
- Easy installation and maintenance
- Dynamic Boost
- Assortment of optical and installation accessories

Dimensions

Unit: mm

Vista Plus Midi 1x100W

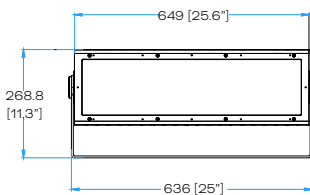

Vista Plus Midi 2x100W

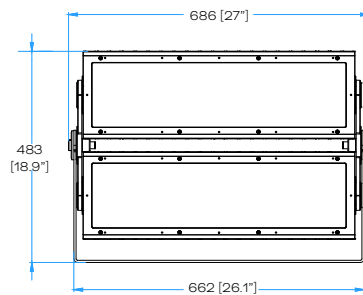

Vista Plus Midi 3x100W

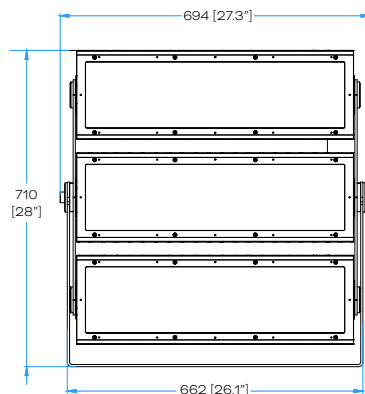

Technologies

- Auto-Addressing / Manual Addressing
- Dynamic Boost

Color Options



RGBA option is on demand

Beam Angles

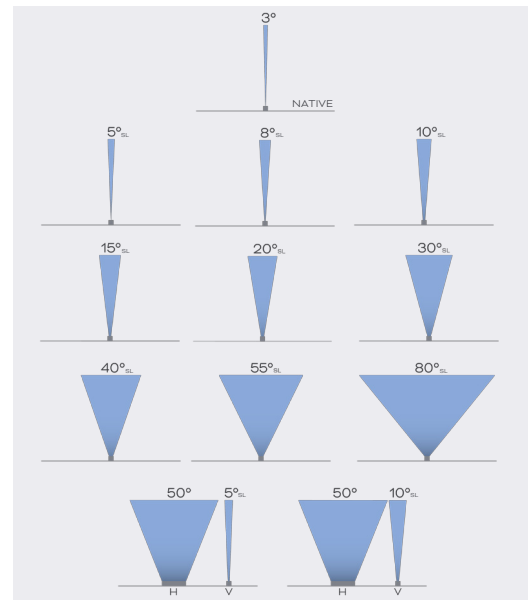

Finish



Product Specifications

Model	1 x 100W		2 x 100W		3 x 100W	
Light Source	Discrete LED x 32		Discrete LED x 64		Discrete LED x 96	
Color Range	RGBW40 (White CCT: 4000K) with Mid Blue or Royal Blue options; Other White CCT and RGBA available on demand					
LED Quantity	RGBW Discrete (D) LED 32 pcs 8R+8G+8B+8W		RGBW Discrete (D) LED 64 pcs 16R+16G+16B+16W		RGBW Discrete (D) LED 96 pcs 24R+24G+24B+24W	
Luminous Flux (White Balance Full on)	5800 lm (3°) with Mid Blue or Royal Blue		11600 lm (3°) with Mid Blue or Royal Blue		17400 lm (3°) with Mid Blue or Royal Blue	
Candela (White Balance Full on)	765600 cd (3°) with Mid Blue or Royal Blue		1531200 cd (3°) with Mid Blue or Royal Blue		2296800 cd (3°) with Mid Blue or Royal Blue	
Efficacy (White Balance Full on)	58 lm/W (3°)					
CRI	≥80 (White LED)					
Beam Angles	3° native ¹ ; 5°, 8°, 10°, 15°, 20°, 30°, 40°, 55°, 80°, 50° x 10°, 50° x 5° via accessory					
Cover Lens	Tempered Glass					
Housing	Die Cast Aluminum					
Housing Finish Options	Standard color: Traxon Signature Gray (RAL7005) Optional color: Gray (RAL7015), Black (RAL9005), White (RAL9003), Custom					
Adjustment Options	1x100W: ±90° vertical 2x100W: ±30° vertical per head, see page 5 for additional information 3x100W: ±30° vertical per outer head, ±20° for center head, See page 6 for additional information					
Mounting	Surface Mount Optional mounting accessories are available					
Dimensions (W x D x H)	649mm x 286.8mm x 144mm / 25.6" x 11.3" x 5.7"		686mm x 483mm x 144.2mm / 27" x 18.9" x 5.7"		694mm x 710mm x 144mm / 27.3" x 28" x 5.7"	
Weight	14.5kg / 31.96lbs.		28.3 kg / 63 lbs.		44 kg / 97 lbs.	
EPA	Vista Plus 1x100W: Front: 1.02 Side: 0.42	Vista Plus 1x100W with Pole mount: Front: 1.3296 Side: 0.6576	Vista Plus 2x100W: Front: 1.032 Side: 0.9096	Vista Plus 2x100W with Pole mount: Front: 1.3392 Side: 1.1472	Vista Plus 3x100W: Front: 1.044 Side: 1.3932	Vista Plus 3x100W with Pole mount: Front: 1.351 Side: 1.632
Regulatory Listing & Safety Approval	cETLus, CE, UKCA, FCC, RoHS, REACH, ASTM B117-16, ANSI 3G					
Operating Temperature	-30°C to +55°C / -22°F to +131°F					
Minimum Starting Temperature	-20°C / -4°F					
Storage Temperature	-40°C to +80°C / -40°F to +176°F					
Environment	Outdoor, IP66, IK08, Coastal Environment (ASTM B117-16)					
Humidity	85%, non-condensing					

Electrical Specifications

Operating Voltage ²	120-277V AC 50/60Hz	
Power Consumption (W)	100	200
Lumen Maintenance	L70 @25°C 81,000hrs	
Power Factor	> 0.9	

System Specifications

Power Supply	AC line
Control	DMX/RDM RDM Personalities ³ ; RGBW equal current mode, RGBW White balance mode (Default, RGBW40 full on to 6500K), Dynamic boost mode, 16-Bit
Addressing Options ⁴	Auto-addressing ON or Auto-addressing OFF (Default as Auto-addressing OFF, address through RDM)

1: 3° native with actual measurement of avg. 3.3°.

2: Auto-switching. Single phase (line, neutral and ground).

3: RDM Personalities

- RGBW Equal Current mode: Each R, G, B, W channel is driven by the same driving current

- RGBW White Balance mode: Each R, G, B, W channel is driven by a modified driving current so that when RGBW is all on, the resulted white is balanced to a defined CCT. In the case of Vista Plus standard RGBW30, when 4 channels are turned on with the same DMX value, the resulted White color is balanced to an approximate 4000K CCT.

- Dynamic Boost mode: In applications where not all channels of a fixture are used, a portion of the unused channels' power would be redirected to the channel(s) that is(are) used to boost the light output. For a RGBW fixture, depending on whether 1, 2 or 3 channels are in used, the redirected power would vary, and in the case that all 4 channels are used, there will be no boost and the efficacy would be lower than Equal current mode/White Balance mode. Ideal for application when mainly 1 to 3 channels are used to offer higher total lumen per color.

4: Auto-addressing Off (i.e. Manual addressing) is as default.

LED CHARACTERISTICS Because LEDs are semiconductor devices, their performances are subject to inherent variability commonly found in semiconductor industry. To improve consistency in performance across the same product, LED manufacturers "sort" LEDs into bins according to different preset parameters, such as forward driving voltage, illumination, etc. Whereas binning is a sorting function, it is not a correction process. Inherent variability in the manufacturing process results always in different binning distributions according to different production lots. Traxon uses automatically binned LEDs on its products, thereby minimizing output variations within the model range.

As with all electronic devices, LED output degrades over time – a term called lumen depreciation. This also explains why it is nearly impossible to expect photometric performances of two LED products with different service life spans to be the same. The rate of LED degrade is a complicated function of many factors such as operating efficiency, duration of continuous operation, and more significantly, environmental conditions (ambient temperature for example). If allowed working under optimal operating temperature range and with good ventilation, LED devices enjoy long service lives over conventional light sources. When using/installing LED devices, care should be taken to ensure that the devices will operate within the operating conditions specified in respective product literature.

This product contains a light source of energy efficiency class G to Regulation (EU) No 2019/2015.

Lumen measurement complies with LM-79-08 standard.

Lumen maintenance is calculated based on LM-80 compliant measurement.

Source Specifications

Length Option	1x100W	2x100W	3x100W
Source	RGBW Discrete (D) LED 32 pcs 8R+8G+8B+8W	RGBW Discrete (D) LED 64 pcs 16R+16G+16B+16W	RGBW Discrete (D) LED 96 pcs 24R+24G+24B+24W
Optics	3°		

Candela Distribution

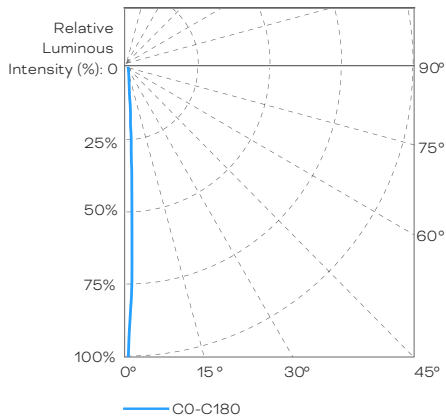

Illuminance at a Distance

	Center Beam LUX/klm	Beam Width	
20m	402	1.12m / 3.67'	65.62'
40m	101	2.23m / 7.32'	131.23'
60m	45	3.35m / 10.99'	196.85'
80m	25	4.47m / 14.67'	262.47'
100m	16	5.59m / 18.34'	328.08'
120m	11	6.70m / 21.98'	393.70'

For Foot-candle divide by 10.7

IES and LDT files are available for download from the Traxon website.

● Horiz. Spread: 3.2°

Light Output - White Balance Mode

	Color	Luminous Flux (lm)	Center Intensity (cd)	Efficacy (lm/W)
1x100W	RGBW (Full On)	5800.0	765600	58.0
	RGB	3183.8	420264	46.8
	Red	798.2	105358	30.8
	Green	2176.4	287288	64.6
	Mid Blue / Royal Blue	280.8 / 73.0	37062 / 9636	15.0 / 3.9
	White 4000K	2688.2	354847	73.8
2x100W	RGBW (Full On)	11600.0	1531200	58.0
	RGB	6367.6	840527	46.8
	Red	1596.3	210716	30.8
	Green	4352.8	574576	64.6
	Mid Blue / Royal Blue	561.5 / 146.0	74123 / 19272	15.0 / 3.9
	White 4000K	5376.5	709695	73.8
3x100W	RGBW (Full On)	17400.0	2296800	58.0
	RGB	9551.4	1260791	46.8
	Red	2394.5	316074	30.8
	Green	6529.3	861864	64.6
	Mid Blue / Royal Blue	842.3 / 219.0	111185 / 28908	15.0 / 3.9
	White 4000K	8064.7	1064542	73.8

Luminaire setting: White Balance mode.

Light Output - Dynamic Boost Mode

	Color	Luminous Flux (lm)	Center Intensity (cd)	Efficacy (lm/W)
1x100W	RGBW (Full On)	4000.0	528000	40.0
	RGB	3148.3	415574	31.5
	Red	1617.8	213551	23.6
	Green	3647.9	481529	50.7
	Mid Blue / Royal Blue	1135.8 / 295.3	149929 / 38981	15.1 / 3.9
	White 4000K	4802.9	633981	62.0
2x100W	RGBW (Full On)	8000.0	1056000	40.0
	RGB	6296.6	831148	31.5
	Red	3235.6	427102	23.6
	Green	7295.9	963058	50.7
	Mid Blue / Royal Blue	2271.6 / 590.6	299857 / 77963	15.1 / 3.9
	White 4000K	9605.8	1267962	62.0
3x100W	RGBW (Full On)	12000.0	1584000	40.0
	RGB	9444.9	1246722	31.5
	Red	4853.4	640652	23.6
	Green	10943.8	1444587	50.7
	Mid Blue / Royal Blue	3407.5 / 885.9	449786 / 116944	15.1 / 3.9
	White 4000K	14408.7	1901943	62.0

Luminaire setting: Dynamic Boost mode.

	Power input cable	Data in / out cable (combined)
Cable Length (open wire)	1830mm [72"]	1830mm [72"]
Cable Outer Diameter	7.8mm [0.31"]	8.1mm [0.32"]

Fixture - 1x100W

Unit: mm

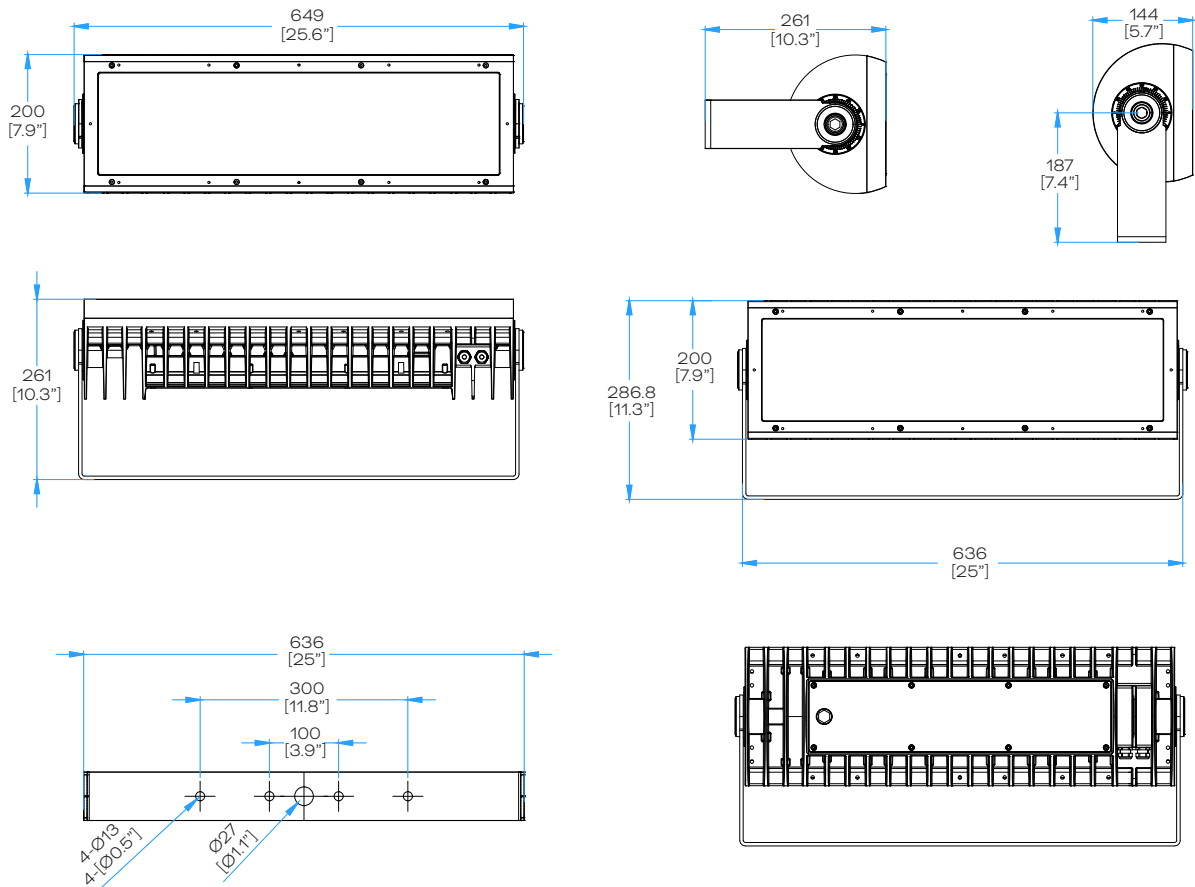

NOTE: Please see CAD files for additional dimensional data.

Fixture - 2x100W

Unit: mm

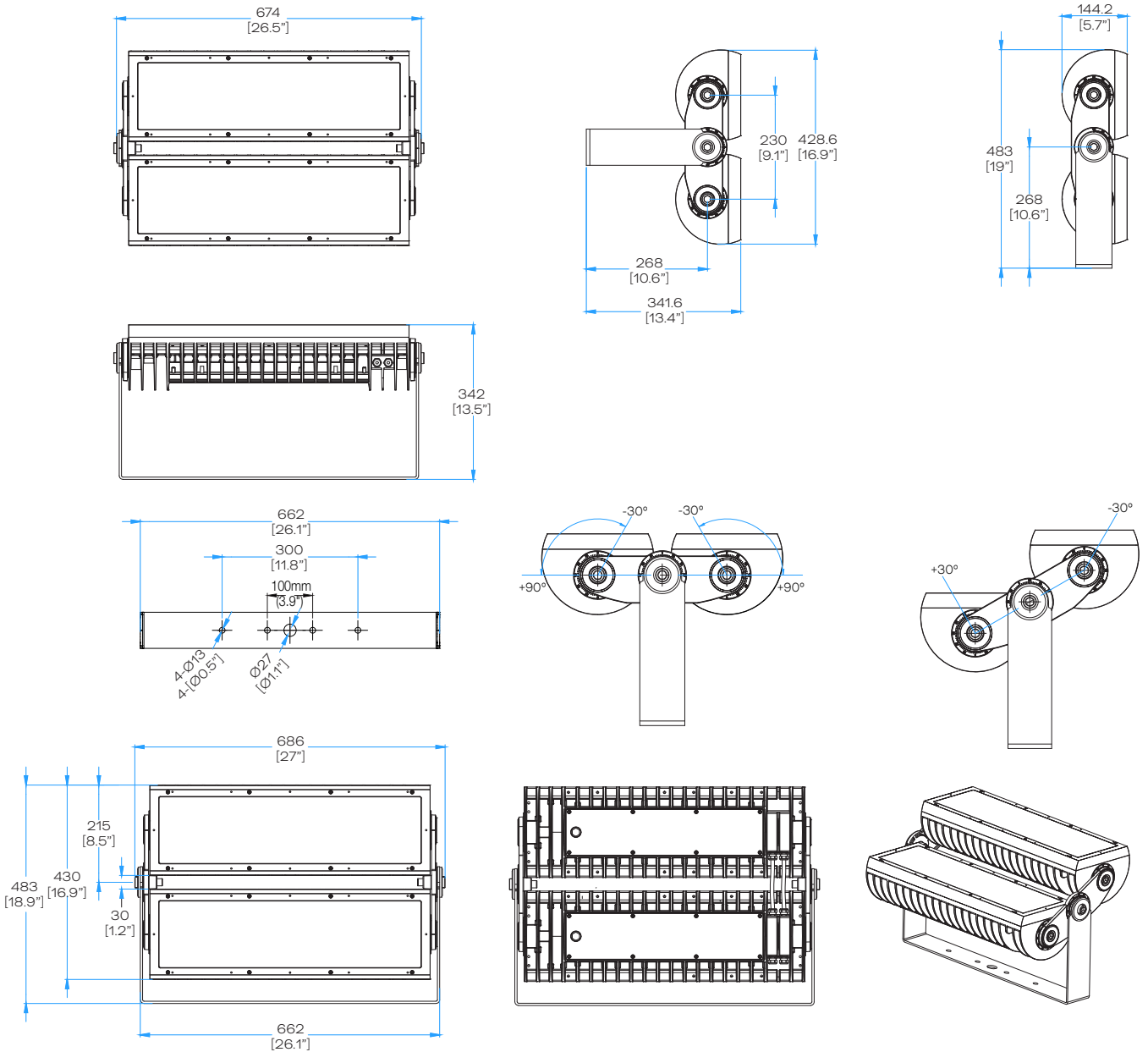

NOTE: Please see CAD files for additional dimensional data.

Fixture - 3x100W

Unit: mm

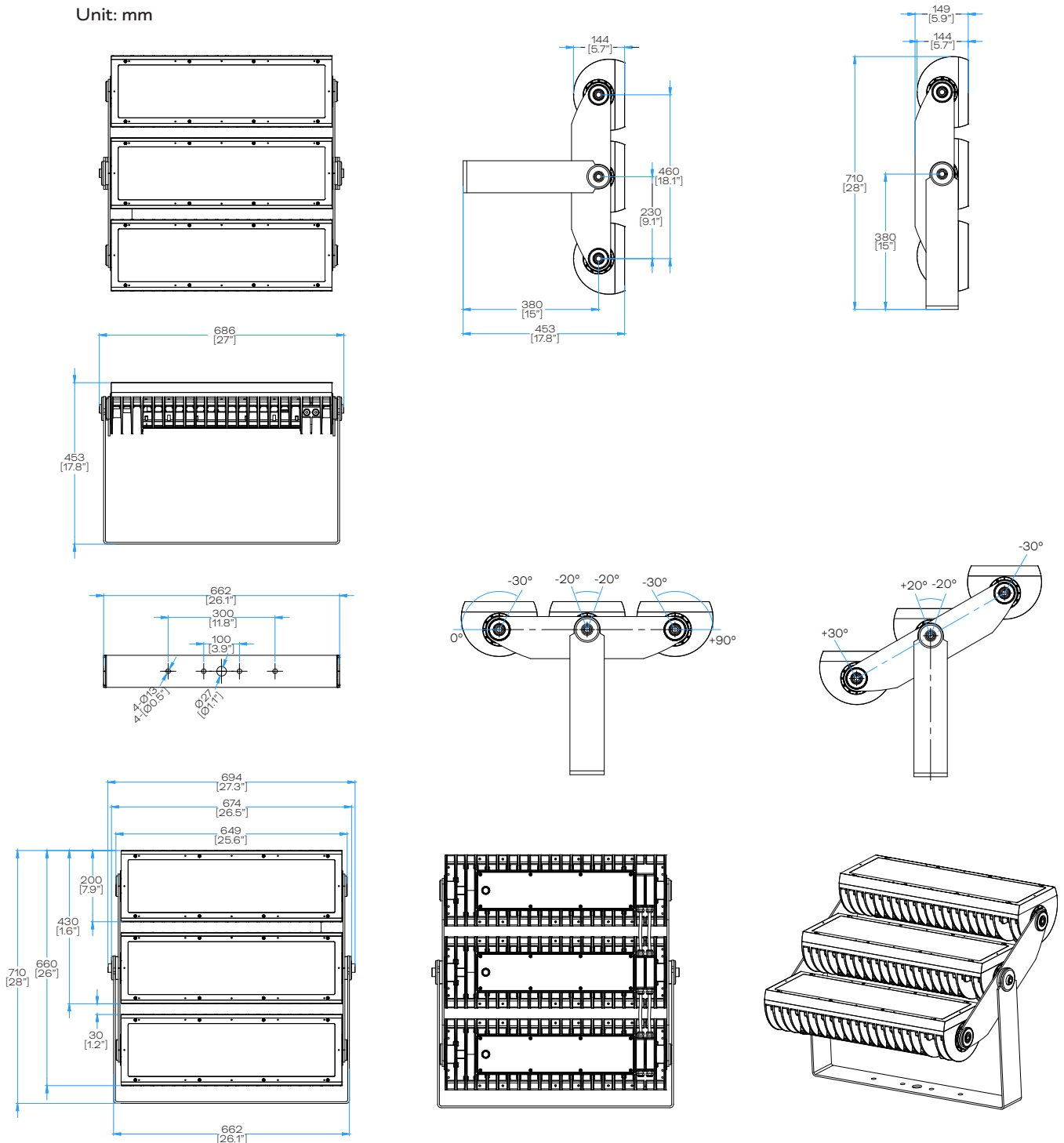

NOTE: Please see CAD files for additional dimensional data.

Mounting Accessories

Model No.	Description	Item Code
N/A	VISTA PLUS POLE-MOUNTING SUPPORT	AM380750055
N/A	VISTA PLUS POLE-MOUNTING SUPPORT BL	AM380900055
N/A	VISTA PLUS POLE-MOUNTING SUPPORT WT	AM381050055

Unit: mm

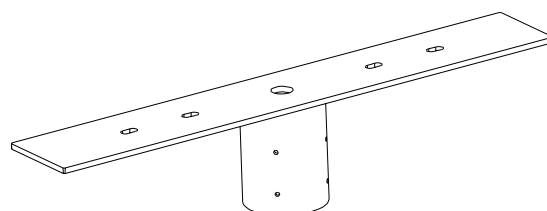
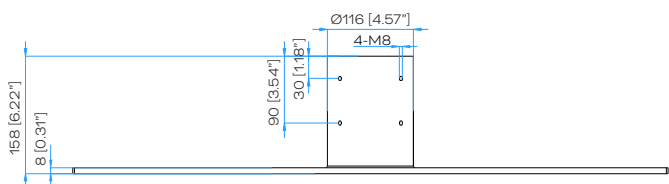
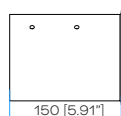
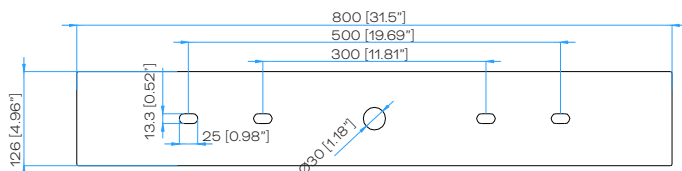

Optical Accessories

Full Glare Shield

Model No.	Description	Item Code
N/A	VISTA PLUS 100W FULL SHIELD	AM410310055
N/A	VISTA PLUS 100W FULL SHIELD BL	AM410450055
N/A	VISTA PLUS 100W FULL SHIELD WT	AM410590055

Unit: mm

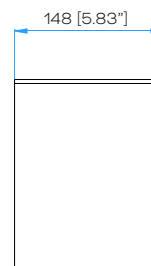
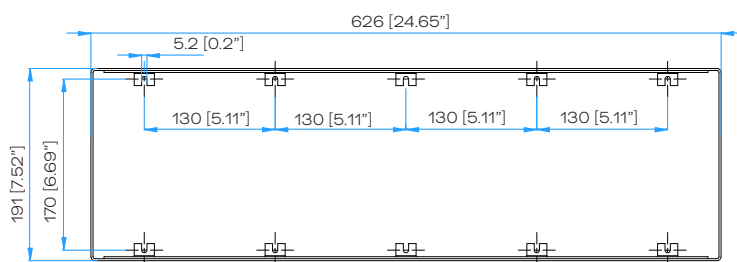

Optical Accessories

Half Glare Shield

Model No.	Description	Item Code
N/A	VISTA PLUS 100W HALF SHIELD	AM410300055
N/A	VISTA PLUS 100W HALF SHIELD BL	AM410440055
N/A	VISTA PLUS 100W HALF SHIELD WT	AM410580055

Unit: mm

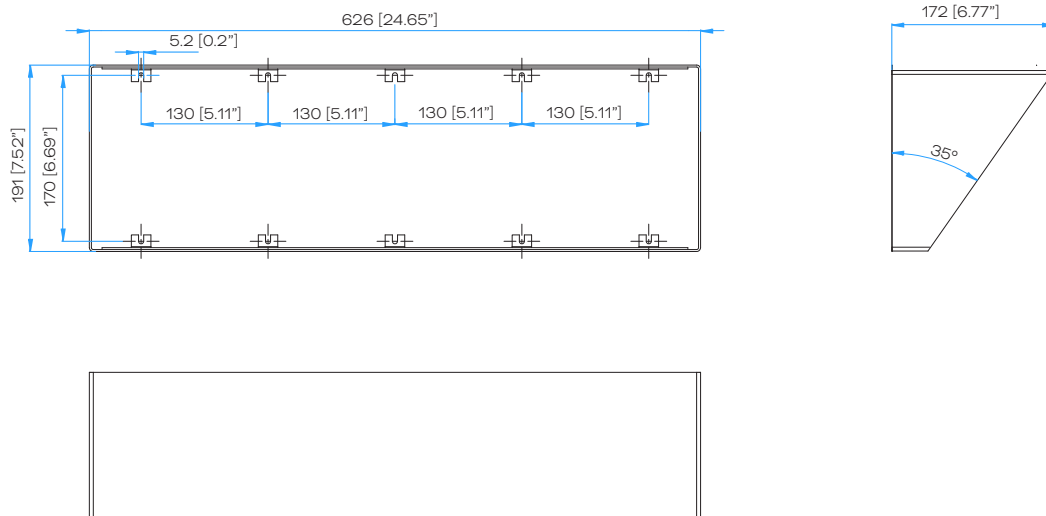

Rock Guard

Model No.	Description	Item Code
N/A	VISTA PLUS 100W ROCK GUARD	AM410320055
N/A	VISTA PLUS 100W ROCK GUARD BL	AM410460055
N/A	VISTA PLUS 100W ROCK GUARD WT	AM410600055

Unit: mm

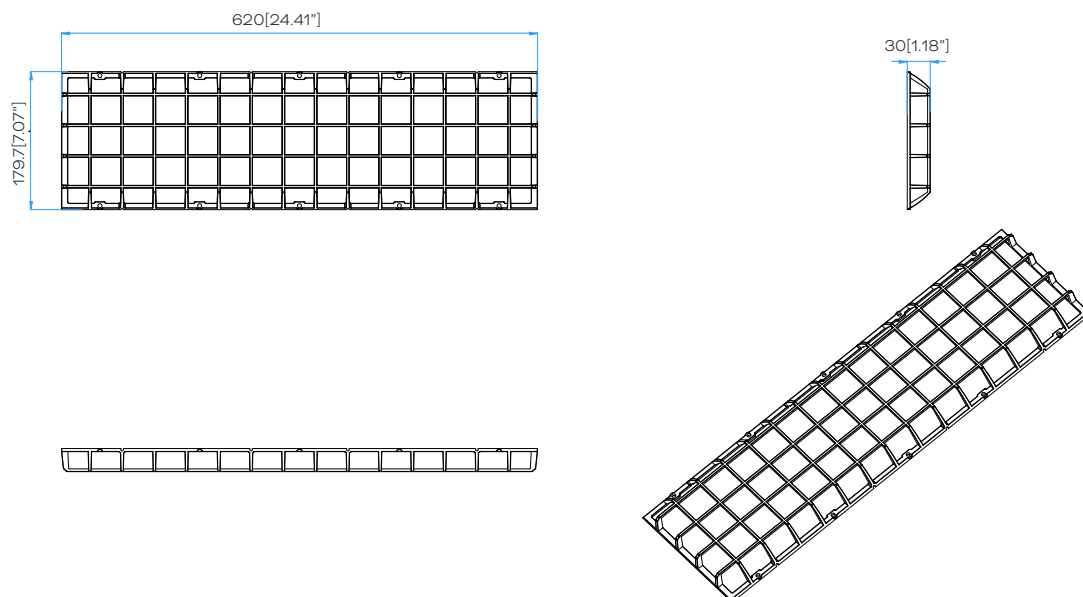

NOTE: Please see CAD files for additional dimensional data.

Optical Accessories

Spread Lens Module

Model No.	Description	Item Code
N/A	VISTA PLUS 100W SPREAD MODULE 5 / 5 BL/ 5 WT	AM410330055 / AM410470055 / AM410610055
N/A	VISTA PLUS 100W SPREAD MODULE 8 / 8 BL/ 8 WT	AM410340055 / AM410480055 / AM410620055
N/A	VISTA PLUS 100W SPREAD MODULE 10 / 10 BL/ 10 WT	AM410350055 / AM410490055 / AM410630055
N/A	VISTA PLUS 100W SPREAD MODULE 15 / 15 BL/ 15 WT	AM410360055 / AM410500055 / AM410640055
N/A	VISTA PLUS 100W SPREAD MODULE 20 / 20 BL/ 20 WT	AM410370055 / AM410510055 / AM410650055
N/A	VISTA PLUS 100W SPREAD MODULE 30 / 30 BL/ 30 WT	AM410380055 / AM410520055 / AM410660055
N/A	VISTA PLUS 100W SPREAD MODULE 40 / 40 BL/ 40 WT	AM410390055 / AM410530055 / AM410670055
N/A	VISTA PLUS 100W SPREAD MODULE 55 / 55 BL/ 55 WT	AM410400055 / AM410540055 / AM410680055
N/A	VISTA PLUS 100W SPREAD MODULE 80 / 80 BL/ 80 WT	AM410410055 / AM410550055 / AM410690055
N/A	VISTA PLUS 100W SPREAD MODULE 50X10 / 50X10 BL/ 50X10 WT	AM410420055 / AM410560055 / AM410700055
N/A	VISTA PLUS 100W SPREAD MODULE 50X5 / 50X5 BL/ 50X5 WT	AM410430055 / AM410570055 / AM410710055

Unit: mm

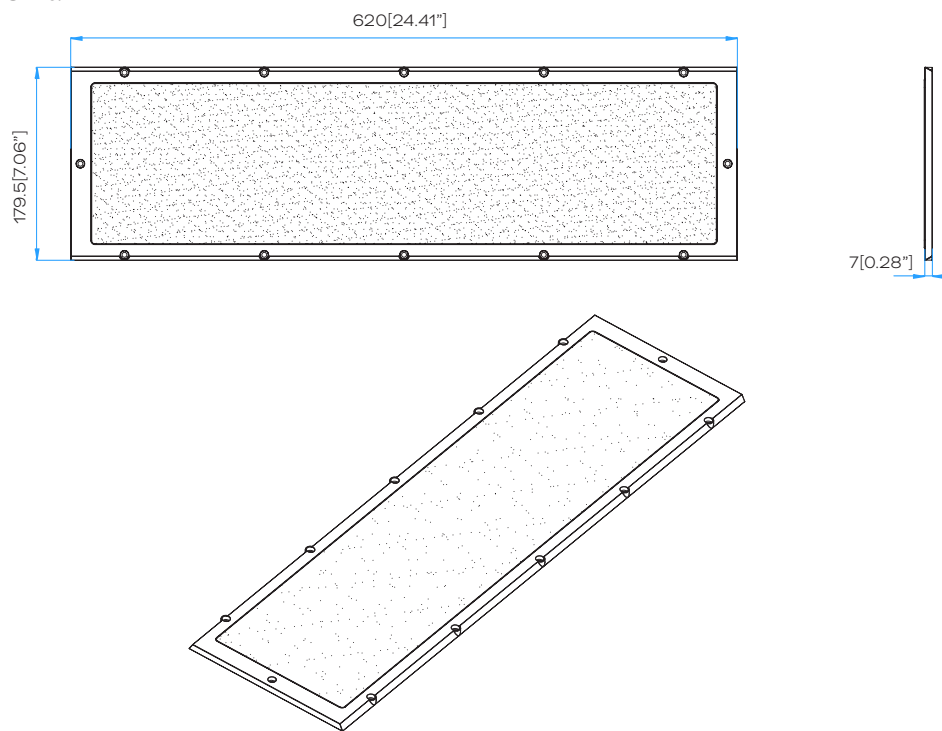

NOTE: Please see CAD files for additional dimensional data.

Wiring Diagram - 1x100W

- Vista Plus fixtures ship with two cable whips: One cable whip for power input, consisting of two wires plus a ground, and one cable whip for DMX512 RDM input/output.
- No more than (32) fixtures on a single DMX512 link, max. 100m total (source to last fixture).
- Each DMX512 link must be properly terminated to prevent signal reflections.
- Data cabling from DMX source to first fixture and between subsequent Vista Plus fixtures shall be Cat5e UTP or higher (stranded type only) or other cable type suitable for DMX communication. Consult DMX standard for additional guidance.

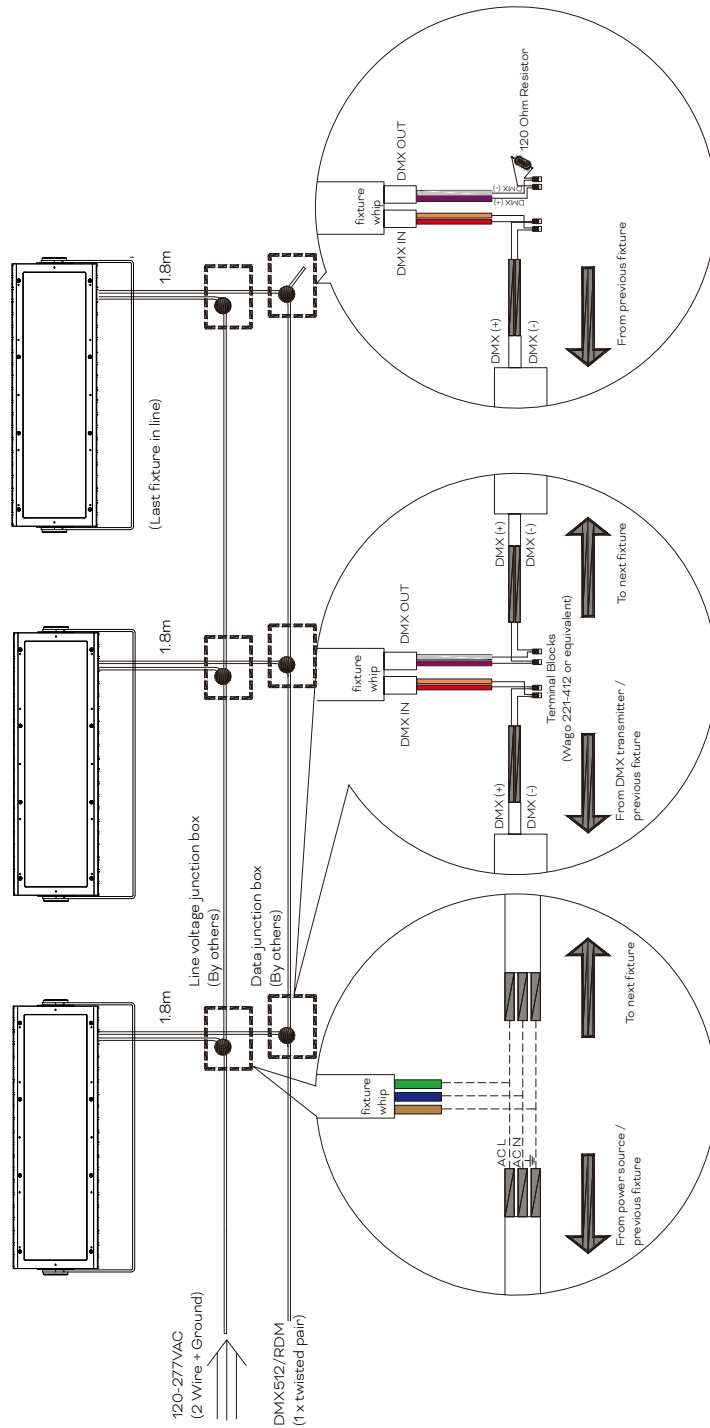

General Notes

- All data cabling must adhere to ANSI E1.11-2008 (R2013) – Entertainment Technology – USITT DMX512-A, Asynchronous Serial Digital Data Transmission Standard for Controlling Lighting Equipment and Accessories.
- Fixture is RDM compatible.
- Fixtures allow a universal input of 120V AC to 277V AC.
- Data termination shall utilize cage clamp terminal blocks, or equivalent. Wire nuts are not permissible and will void warranty.
- The method of line voltage termination, both for data and power, is at the discretion of the installing contractor, and/or engineer. Splicing and/or joining of cables must adhere to all applicable electrical codes.
- Cables must be spliced/joined in a weatherproof enclosure/junction box, which is to be properly rated and provided by others.
- Each fixture has 1.8m DMX data cable (total 3.6m DMX in and DMX out); it should be included in the 100m total calculation.

Wiring Diagram - 2x100W

— Vista Plus fixtures ship with two cable whips: One cable whip for power input, consisting of two wires plus a ground, and one cable whip for DMX512 RDM input/output.

— No more than (32) fixtures on a single DMX512 link, max. 100m total (source to last fixture).

— Each DMX512 link must be properly terminated to prevent signal reflections.

— Data cabling from DMX source to first fixture and between subsequent Vista Plus fixtures shall be Cat5e UTP or higher (stranded type only) or other cable type suitable for DMX communication. Consult DMX standard for additional guidance.

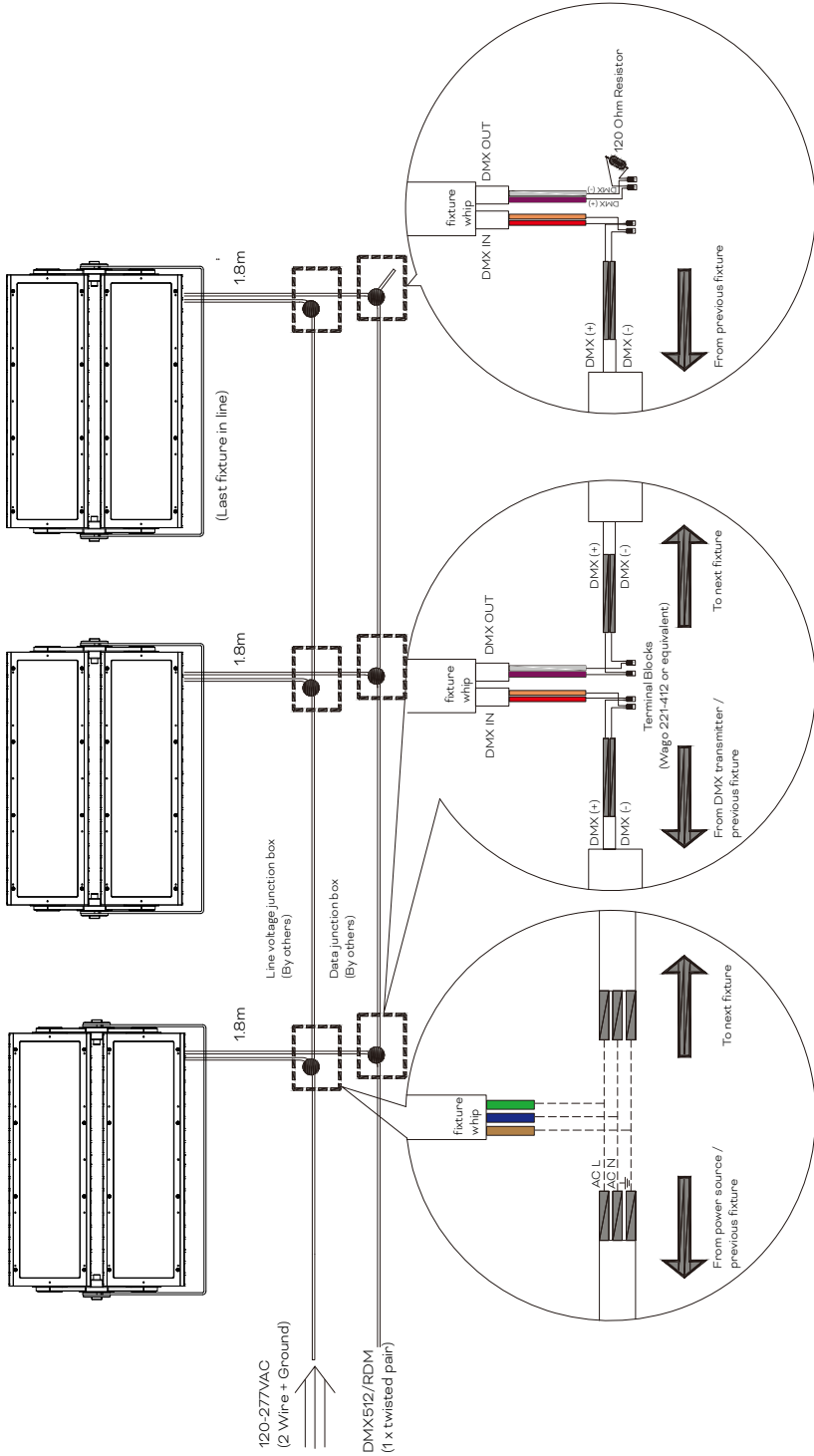

General Notes

- All data cabling must adhere to ANSI E1.11-2008 (R2013) – Entertainment Technology – USITT DMX512-A, Asynchronous Serial Data Transmission Standard for Controlling Lighting Equipment and Accessories.
- Fixture is RDM compatible.
- Fixtures allow a universal input of 120V AC to 277V AC.
- Data termination shall utilize cage clamp terminal blocks, or equivalent. Wire nuts are not permissible and will void warranty.
- The method of line voltage termination, both for data and power, is at the discretion of the installing contractor, and/or engineer. Splicing and/or joining of cables must adhere to all applicable electrical codes.
- Cables must be spliced/joined in a weatherproof enclosure/junction box, which is to be properly rated and provided by others.
- Each fixture has 1.8m DMX data cable (total 3.6m DMX in and DMX out), it should be included in the 100m total calculation.

Wiring Diagram - 3x100W

- Vista Plus fixtures ship with two cable whips: One cable whip for power input, consisting of two wires plus a ground, and one cable whip for DMX512 RDM input/output.
- No more than (32) fixtures on a single DMX512 link, max. 100m total (source to last fixture).
- Each DMX512 link must be properly terminated to prevent signal reflections.
- Data cabling from DMX source to first fixture and between subsequent Vista Plus fixtures shall be Cat5e UTP or higher (stranded type only) or other cable type suitable for DMX communication. Consult DMX standard for additional guidance.

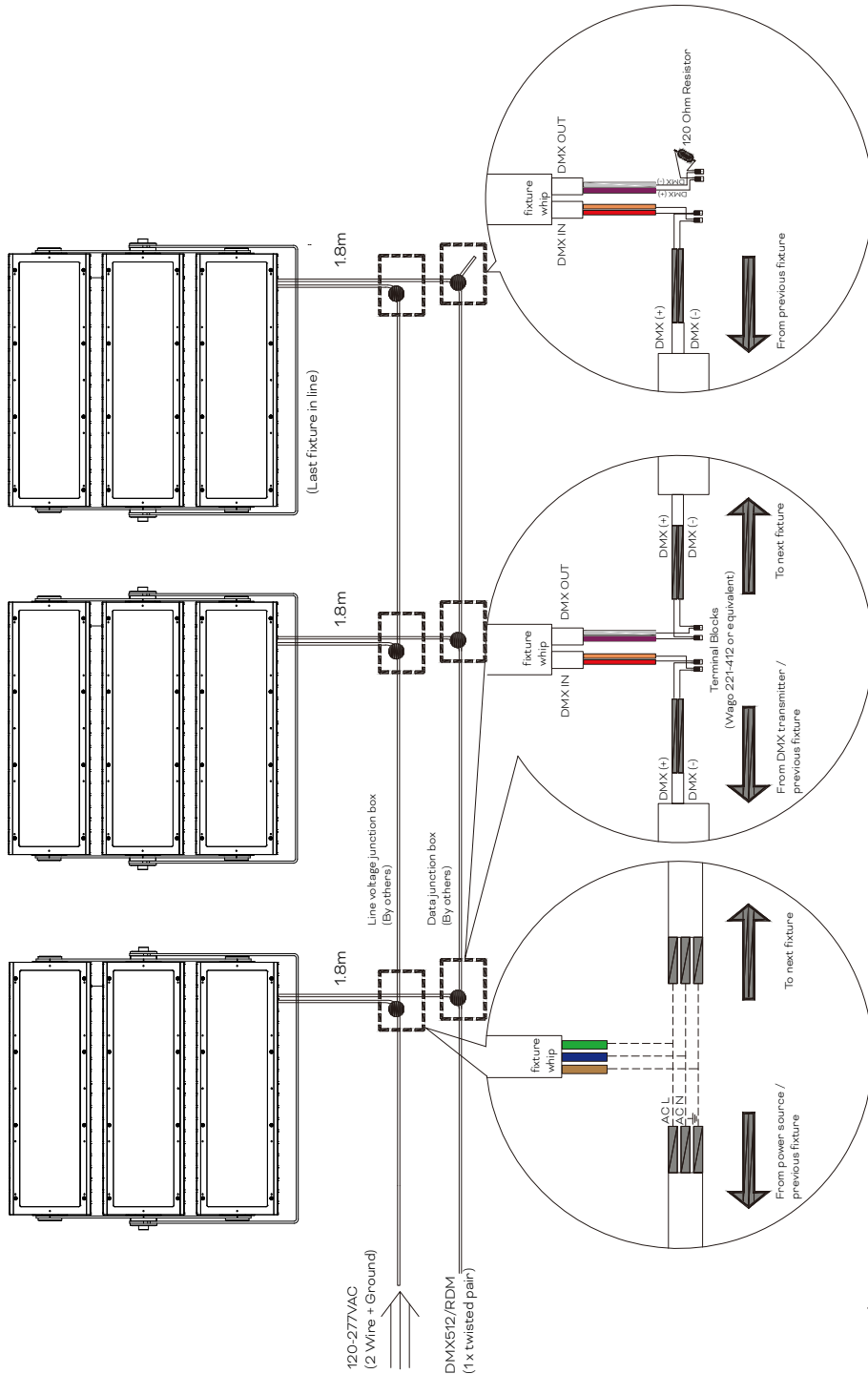

- General Notes**
- All data cabling must adhere to ANSI E11-2008 (R2013) – Entertainment Technology – USITT DMX512-A, Asynchronous Serial Digital Data Transmission Standard for Controlling Lighting Equipment and Accessories.
 - Fixture is RDM compatible.
 - Fixtures allow a universal input of 120V AC to 277V AC.
 - Data termination shall utilize cage clamp terminal blocks, or equivalent. Wire nuts are not permissible and will void warranty.
 - The method of line voltage termination, both for data and power, is at the discretion of the installing contractor, and/or engineer. Splicing and/or joining of cables must adhere to all applicable electrical codes.
 - Cables must be spliced/joined in a weatherproof enclosure/junction box, which is to be properly rated and provided by others.
 - Each fixture has 1.8m DMX data cable (total 3.6m DMX in and DMX out), it should be included in the 100m total calculation.

Model Number Builder

VI.	PL.	N	1	1	N	1	1	1	1	1	N	0	0
		Number of Head	Wattage per head	LED	CCT	Optics	Control	Pixel	Approbation	Mounting/ Add On	Color Finish	Cable/ Connector	
		1: 1-head	1 - 100W AC per Midi head	1 - RGBW	1 - RGBW40 (4000K with Mid-Blue)	1 - 3°	1 - DMX/RDM	1 - 1 pixel per head	1 - CE & ETL	1 - 3G vibration	0 - TX Signature Gray	0 - Standard version	
		2: 2-head			2 - RGBW40 (4000K with Royal-Blue)						1 - Gray		
		3: 3-head			3 - RGBA						2 - Black		
											3 - White		
EXAMPLE		VISTA PLUS MIDI 1x100W AC RGBW40(D) W/MID-BLUE 3° TX-GRAY CE Model Number: VI.PL.11111111100											
VI.	PL.	1	1	1	1	1	1	1	1	1	1	0	0

Project Model Number

CL.	PL.	1	1	1	1	1	1	1	1	1	0	0

Fixture

Model No.	Description	Item Code
VI.PL.11111111100	VISTA PLUS MIDI 1x100W AC RGBW40(D) W/MID-BLUE 3° TX-GRAY	DL26103654255
VI.PL.11211111100	VISTA PLUS MIDI 1x100W AC RGBW40(D) W/ROYAL-BLUE 3° TX-GRAY	DL26103654355
VI.PL.21111111100	VISTA PLUS MIDI 2x100W AC RGBW40(D) W/MID-BLUE 3° TX-GRAY	DL26103654755
VI.PL.21211111100	VISTA PLUS MIDI 2x100W AC RGBW40(D) W/ROYAL-BLUE 3° TX-GRAY	DL26103654855
VI.PL.31111111100	VISTA PLUS MIDI 3x100W AC RGBW40(D) W/MID-BLUE 3° TX-GRAY	DL26103655255
VI.PL.31211111100	VISTA PLUS MIDI 3x100W AC RGBW40(D) W/ROYAL-BLUE 3° TX-GRAY	DL26103655355

Mounting Accessories

Model No.	Description	Item Code
N/A	VISTA PLUS POLE-MOUNTING SUPPORT	AM380750055
N/A	VISTA PLUS POLE-MOUNTING SUPPORT BL	AM380900055
N/A	VISTA PLUS POLE-MOUNTING SUPPORT WT	AM381050055
N/A	PROPOINT TERMINATION KIT	AM243520054

Optical Accessories

Model No.	Description	Item Code
N/A	VISTA PLUS 100W HALF SHIELD	AM410300055
N/A	VISTA PLUS 100W FULL SHIELD	AM410310055
N/A	VISTA PLUS 100W ROCK GUARD	AM410320055
N/A	VISTA PLUS 100W SPREAD MODULE 5	AM410330055
N/A	VISTA PLUS 100W SPREAD MODULE 8	AM410340055
N/A	VISTA PLUS 100W SPREAD MODULE 10	AM410350055
N/A	VISTA PLUS 100W SPREAD MODULE 15	AM410360055
N/A	VISTA PLUS 100W SPREAD MODULE 20	AM410370055
N/A	VISTA PLUS 100W SPREAD MODULE 30	AM410380055
N/A	VISTA PLUS 100W SPREAD MODULE 40	AM410390055
N/A	VISTA PLUS 100W SPREAD MODULE 55	AM410400055
N/A	VISTA PLUS 100W SPREAD MODULE 80	AM410410055
N/A	VISTA PLUS 100W SPREAD MODULE 50X10	AM410420055
N/A	VISTA PLUS 100W SPREAD MODULE 50X5	AM410430055

Optical Accessories

Model No.	Description	Item Code
N/A	VISTA PLUS 100W HALF SHIELD BL	AM410440055
N/A	VISTA PLUS 100W FULL SHIELD BL	AM410450055
N/A	VISTA PLUS 100W ROCK GUARD BL	AM410460055
N/A	VISTA PLUS 100W SPREAD MODULE 5 BL	AM410470055
N/A	VISTA PLUS 100W SPREAD MODULE 8 BL	AM410480055
N/A	VISTA PLUS 100W SPREAD MODULE 10 BL	AM410490055
N/A	VISTA PLUS 100W SPREAD MODULE 15 BL	AM410500055
N/A	VISTA PLUS 100W SPREAD MODULE 20 BL	AM410510055
N/A	VISTA PLUS 100W SPREAD MODULE 30 BL	AM410520055
N/A	VISTA PLUS 100W SPREAD MODULE 40 BL	AM410530055
N/A	VISTA PLUS 100W SPREAD MODULE 55 BL	AM410540055
N/A	VISTA PLUS 100W SPREAD MODULE 80 BL	AM410550055
N/A	VISTA PLUS 100W SPREAD MODULE50X10 BL	AM410560055
N/A	VISTA PLUS 100W SPREAD MODULE50X5 BL	AM410570055
N/A	VISTA PLUS 100W HALF SHIELD WT	AM410580055
N/A	VISTA PLUS 100W FULL SHIELD WT	AM410590055
N/A	VISTA PLUS 100W ROCK GUARD WT	AM410600055
N/A	VISTA PLUS 100W SPREAD MODULE 5 WT	AM410610055
N/A	VISTA PLUS 100W SPREAD MODULE 8 WT	AM410620055
N/A	VISTA PLUS 100W SPREAD MODULE 10 WT	AM410630055
N/A	VISTA PLUS 100W SPREAD MODULE 15 WT	AM410640055
N/A	VISTA PLUS 100W SPREAD MODULE 20 WT	AM410650055
N/A	VISTA PLUS 100W SPREAD MODULE 30 WT	AM410660055
N/A	VISTA PLUS 100W SPREAD MODULE 40 WT	AM410670055
N/A	VISTA PLUS 100W SPREAD MODULE 55 WT	AM410680055
N/A	VISTA PLUS 100W SPREAD MODULE 80 WT	AM410690055
N/A	VISTA PLUS 100W SPREAD MODULE50X10 WT	AM410700055
N/A	VISTA PLUS 100W SPREAD MODULE50X5 WT	AM410710055

