

ARCHISHAPE® 2.0 Linear MAXI

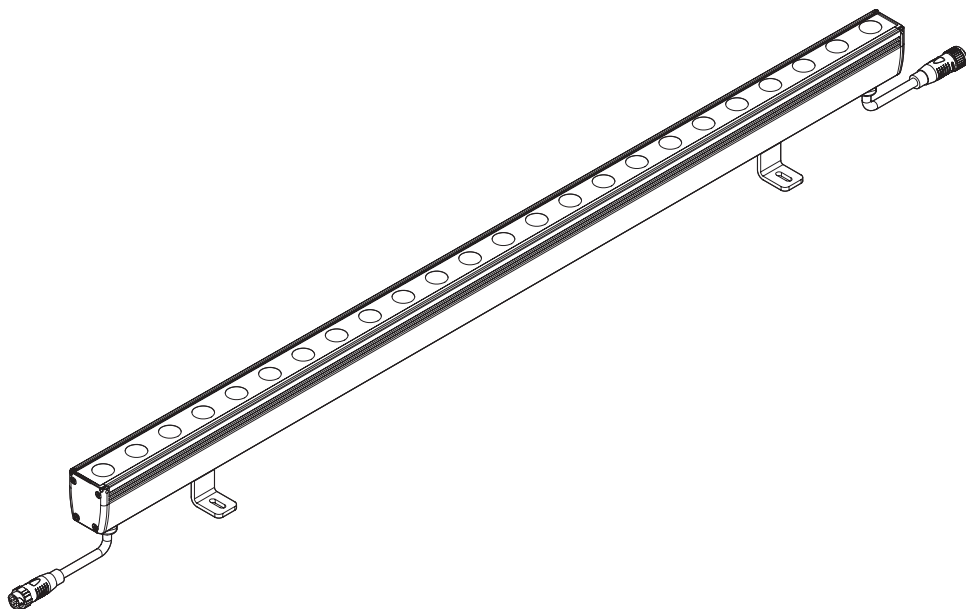

- Please read instruction carefully before assembling and installation
- Please keep instruction as reference in the future

OSRAM

ARCHISHAPE® 2.0 Linear MAXI

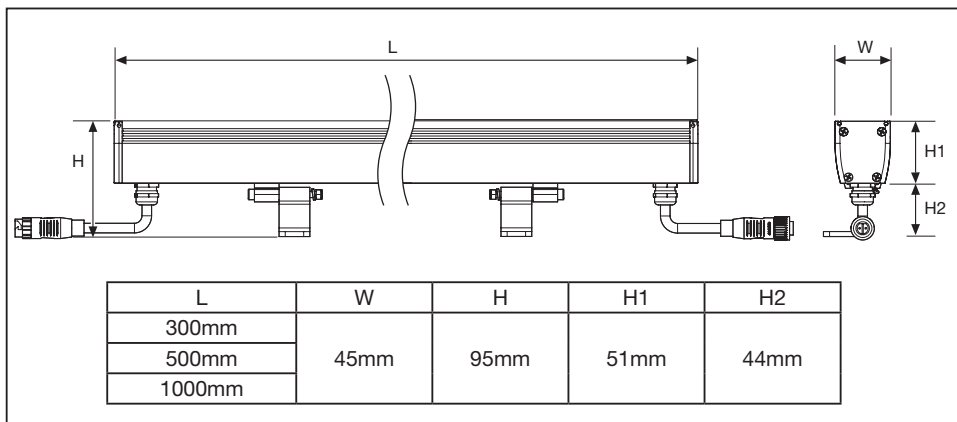

	Weight (g)	Rated power (W)	Input current (A)	Rated voltage (V)	IP	Maximum projected area (m ²)
300mm	1000	14	0.58	DC 24	66	0.021
500mm	1400	21	0.88			0.036
1000mm	2500	42	1.75			0.071

	Max. connected qty. (1.5mm ² master cable)	
	Rated power	24V DC
300mm	14W	13 pcs
500mm	21W	9 pcs
1000mm	42W	4 pcs

Above calculation is based on 1.5mm² cable. Please consult local sales for other calculations. Signal amplifier is required when the distance between adjacent luminaires is more than 80 meters, or more than 32 luminaires are connected.

ARCHISHAPE® 2.0 Linear MAXI

1

	D
	Max
300mm	100mm
500mm	300mm
1000mm	800mm

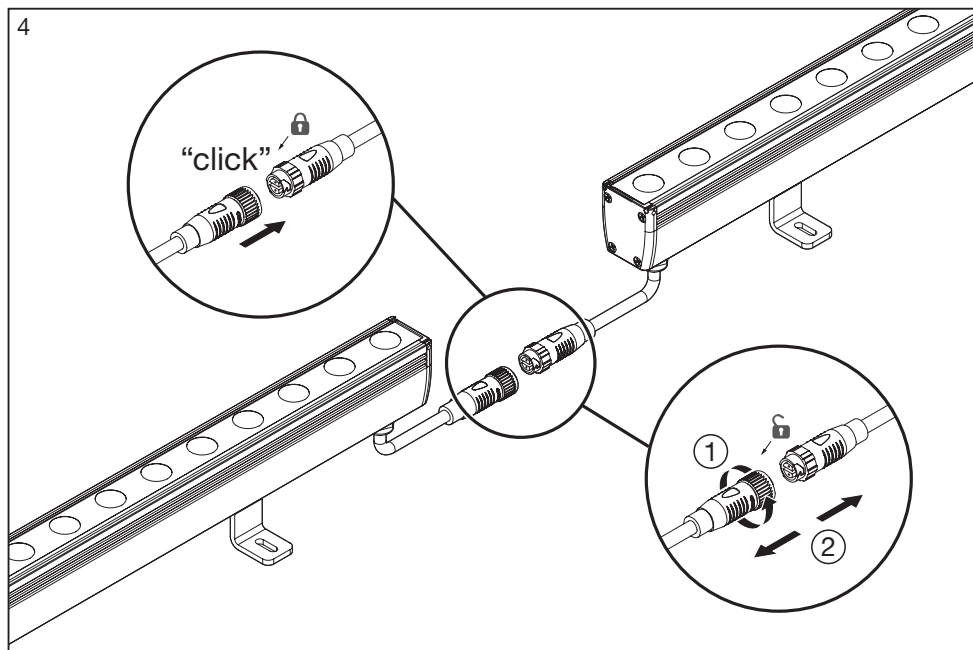
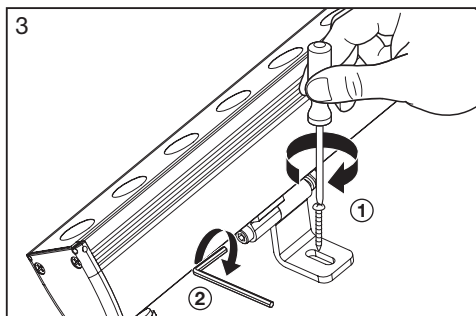
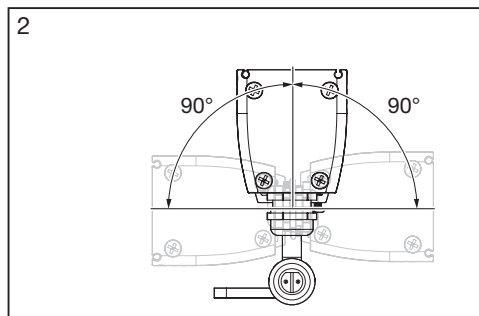

On Off version - Accessories

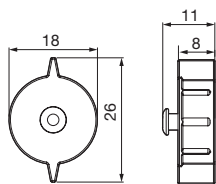

ASL 2&3-pin Connector Socket End Cap CE
AM259050055

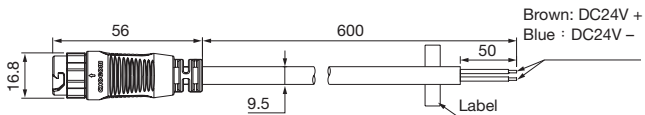

ASL 2-pin DC Power Starter Cable 600 CE
AM251590055

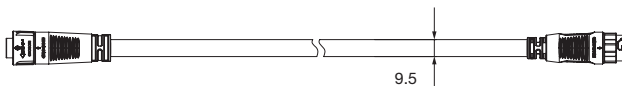

ASL 2-pin DC Interconnection CAB 1000 CE AM251600055

5A - On Off version

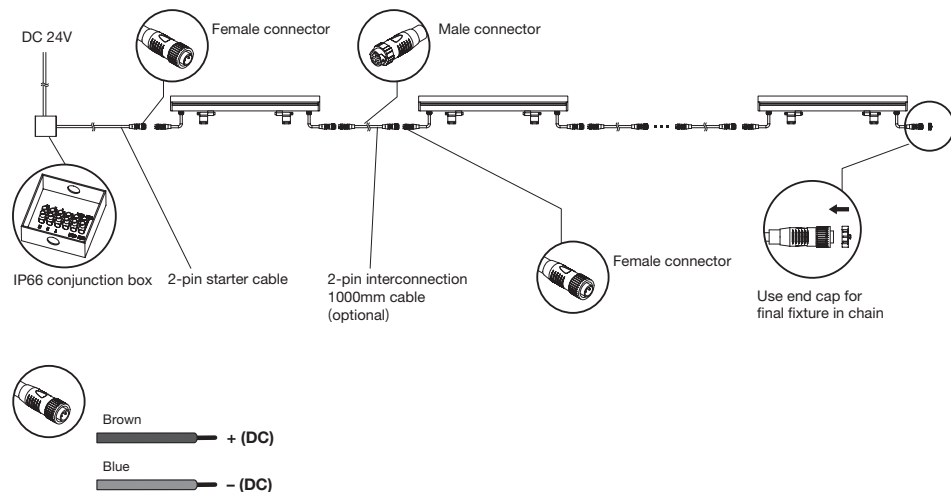

DMX version - Accessories

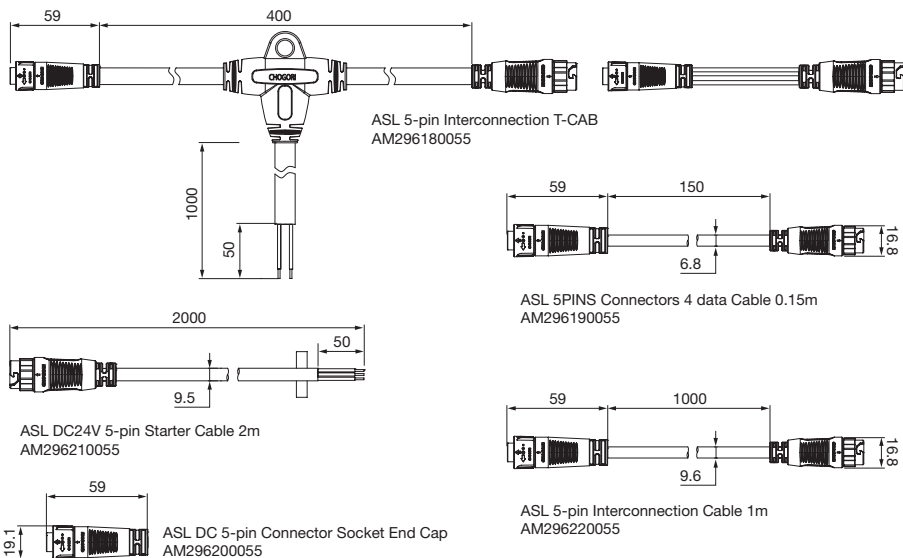

5B - DMX version

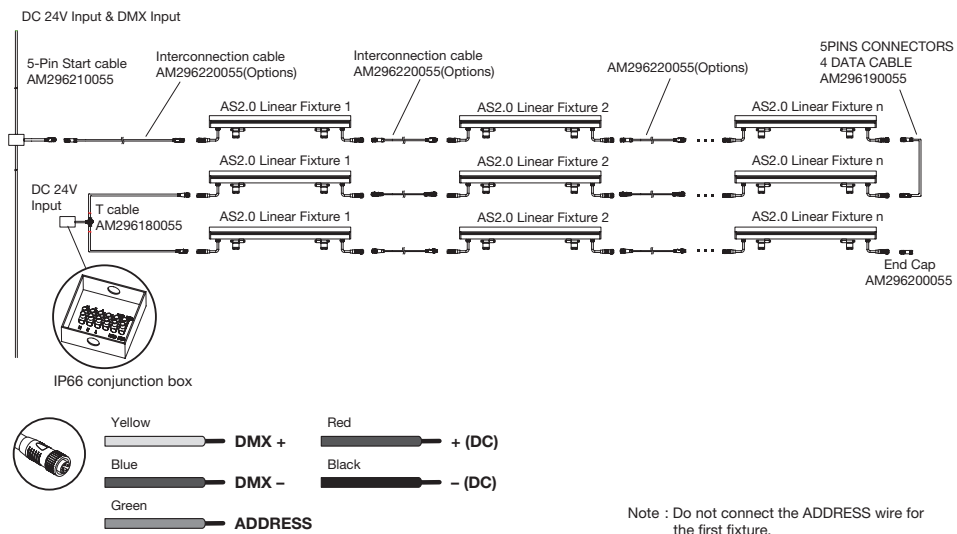

ARCHISHAPE® 2.0 Linear MAXI

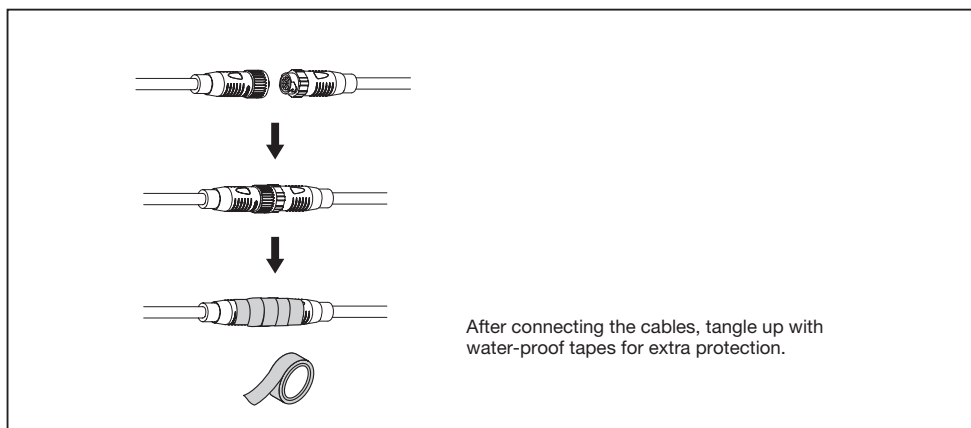
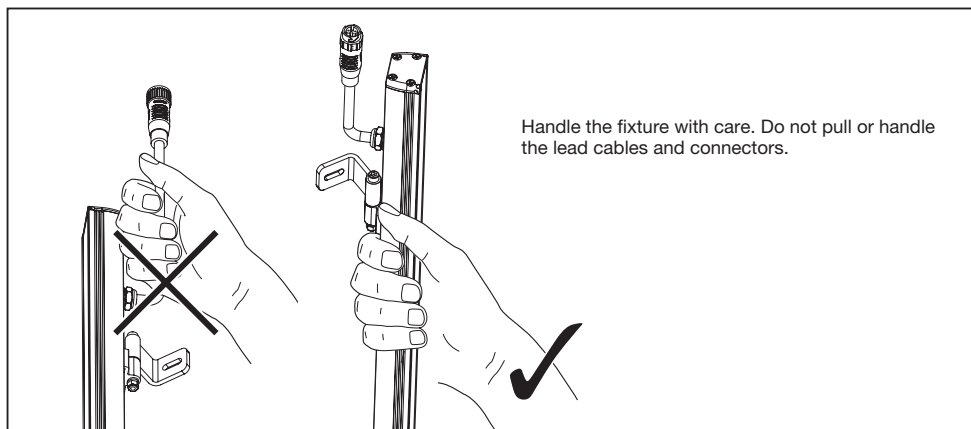



WARNING:

1. The luminaire should be installed and maintained by qualified electrician and wired in accordance with the latest IEE electrical regulations or the national regulations. Terminal block not included. Installation may require advice from a qualified person.
2. Make sure the products are grounded.
3. The power must be OFF during installation and maintenance.
4. The external flexible cable or cord of this luminaire cannot be replaced. If the cord is damaged, the luminaire shall be destroyed.
5. The light source of this luminaire can not be exchanged; if the user needs to exchange the light source (e.g. the light source is at the end of its life cycle), then the completed luminaire has to be exchanged.
6. Installation: Surface mounted. Outdoor use. No mounting height limited.
7. Make sure the products are securely installed.
8. The housing might become hot during or after operation.
9. No modification on the product is allowed.
10. Suitable for indoor and outdoor use. Do not immerse in water.
11. Not suitable for ordinary lighting in household room illumination.
12. Power supply system should be equipped with SPD (Surge protection Device) accordance with electrical regulations.
13. For DMX version, reinforced insulation has been complied between LV supply and control conductors.



INSTRUCTION:

1. Order all power supplies / cables / connectors / controllers / signal amplifiers / IP66 junction boxes separately.
2. Connect luminaires to main power supply & DMX cable by IP66 junction box (purchased by customer). Make sure the wiring is correct and reliable. Suggest to wrap the connectors by waterproofed tape for security.
3. Regular check and cleaning are required.
4. Do not stare at the operating light source. The luminaire should be positioned so that prolonged staring into the luminaire at a distance closer than 2m is not expected.
5. Suggest to use shielded twisted-pair as signal cable. Terminate each DMX line with a 120 ohm resistor to get stable DMX signal.
6. DMX version requires addressing tool to address the luminaires.
7. Signal amplifier is recommended when the distance between controller and the first luminaire is over 100 meters.



IEC 60598-1:2014

IEC 60598-1:2014/AMD1:2017

IEC 60598-2-1:1979

IEC 60598-2-1:1979/AMD1:1987

© 欧司朗 (中国) 照明有限公司
广东省佛山市工业北路1号 邮编: 528000

客服热线: 400 882 1836
OSRAM CHINA LIGHTING LTD.
No. 1 North Industrial Road, Foshan,
Guangdong. Postal code: 528000
www.osram.com.cn

© PT OSRAM Indonesia
COWELL Tower 8th Floor
Jl. Senen Raya No. 135
Jakarta Pusat 10410
www.osram.com

© บริษัท ออสแรม (ประเทศไทย) จำกัด
อาคารชาบูอิสสระหาวเวอร์ 2 ชั้น 19 2922/251
ถนนเพชรบุรีตัดใหม่ แขวงบางกะปิ เขตห้วยขวาง
กรุงเทพมหานคร 10310
www.osram.com

© OSRAM (Malaysia) Sdn Bhd
(Company No: 491867 X)
L8-02, 8th Floor, Tropicana City Office Tower,
No.3, Jalan SS20/27,
47400 Petaling Jaya, Selangor, Malaysia
www.osram.com

© OSRAM Lighting Private Ltd.
1st Floor, IFFCO, Surinder Jhakhar Bhavan,
Plot No. 3,
Sector-32, Gurgaon-122001, Haryana, India
Consumer care cell (Address as per above)
Toll free number: 18004190426
E-mail id: customercare@osram.com
www.osram.com

© 주식회사 오스람
서울시 강남구 삼성로 554 예성빌딩 3 층
(06165)
AS: 080 349 0365
www.osram.kr

© OSRAM Lighting Pte Ltd
988 Toa Payoh North
03-01 / 07 / 08
Singapore 319002
www.osram.com

© Traxon Technologies Ltd.
213 Wireless Centre,
3 Science Park East Avenue,
Science Park, Shatin,
New Territories, Hong Kong
Phone: +852 2943 3488
www.osram.com

© OSRAM GmbH
Karl-Schurz-Straße 38
33100 Paderborn
Germany
www.osram.com

IP66



C10449057
G15065767
2019-07-03

www.osram.com