

DALI-2 Multi Sensor LS/MD Instructions



Highlights

- PIR motion detection
- Motion sensor instance type 3 (303)
- Illuminance measurement
- Light sensor instance type 4 (304)
- Recessed ceiling installation
- Cost-effective solution for energy savings
- Compatible with universal DALI-2 compliant central control unit that supports sensor input devices

Delivery scope

Identcode

- e:cue DALI-2 Multi Sensor LS/MD AM466320055
- Welcome note
- Instructions

Optional accessories

- SYMPL dali Node AB444230035

Safety & Warnings



- Do not install with power applied to device.
- Do not expose the device to moisture.
- Read the instructions prior to installation.



For further product information and downloads see www.ecue.com.

Product specifications

Dimensions (W x H x D)	83 x 83 (67 x 67) x 21 mm / 3.27 x 3.27 (2.64 x 2.64) x 0.83 in
Cutting Hole	70 ... 73 mm / 2.76 .. 2.87 in
Material / Color	ABS / White
Wire Gauge	0.2 ... 1.3 mm ²
Stripping Length	7 ... 9 mm / 0.28 ... 0.35 in
Certificates	CE, DALI-2, RoHS

Electrical information

Power Supply	DALI Bus
Max. DALI Current Draw	6 mA
Control	DALI
Marking Terminals	DA, DA
Motion Detection Indicator	Red (motion detection)
DALI Indicator	Green (DALI)

Sensing

Motion Detection (62386 - 303)	PIR sensor
Light Sensor (62386 - 304)	Event: 0 ... 1000 Lux (10 bit), resolution: 10 Lux
Mounting Height	recommended height: 2.5 m / 8.2 ft
Detection Angle	130 °
Function	Configurable

Environment

Operating Temperature Range	0 ... 40 °C / 32 .. 104 °F, indoor use only
Operating Humidity	0 ... 95% (non condensing)
Storage Temperature Range	-20 ... 70 °C / -4 ... 158 °F
Storage Humidity	15 ... 90% (non condensing)



Dimensions

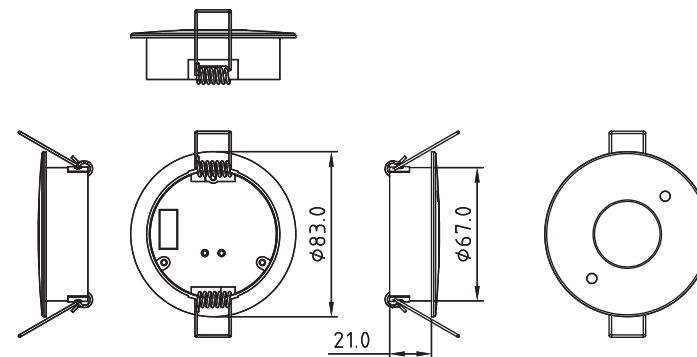

Detection Coverage

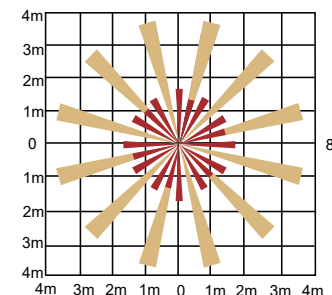
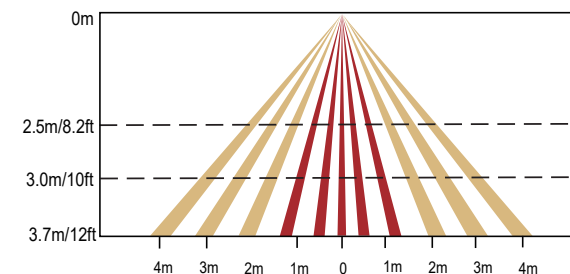

- Slow movement (person moving < 0.3m/s)
- Quick movement (person moving > 0.4m/s)

Connectors & Interfaces

Motion sensor indicator (Red): flashes once when motion is being detected. Stays off when no motion is being detected.

DALI signal indicator (Green): flashes when receives DALI signal from application controller and reports event messages to application controller.

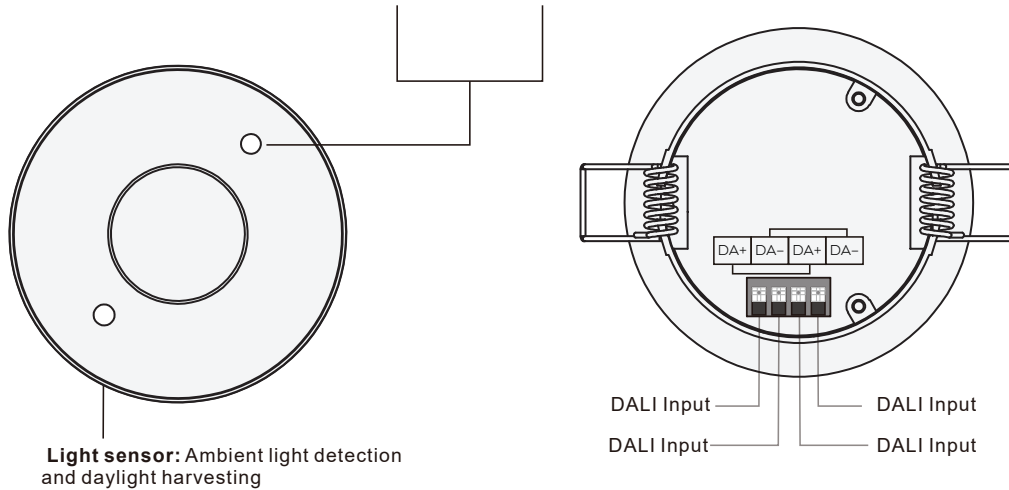

Installation

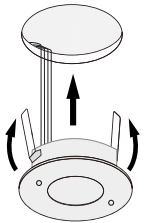

Prerequisite: mounting hole of 70 .. 73 mm.

Connect the DALI wires to the device.

Bend the springs up and push the device through the hole in the ceiling. When fully inserted, the springs snap back to hold the device in place. To avoid injury, take care when bending springs.

The installation is completed.

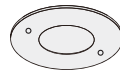

Installation Precautions

- Avoid areas with frequent temperature changes: Keep away from air conditioners, fans, refrigerators, ovens, and other objects that cause rapid temperature changes. The detection effectiveness of PIR motion sensors is closely related to temperature fluctuations, and vents or heat sources can lead to false alarms.
- Avoid areas with significant air flow.
- Avoid facing glass doors and windows directly: 1) Do not face glass doors and windows directly to avoid interference from strong light. 2) Avoid complex environments outside doors and windows, such as direct sunlight, crowds, and moving vehicles.
- Avoid installing opposite large, constantly moving objects: Large objects with significant motion can cause sudden changes in airflow within the detection area, leading to false alarms. Outdoor PIR motion sensors should not be installed opposite large trees or tall bushes.
- Avoid areas with screens, furniture, large potted plants, or other obstacles within the detection range.
- Avoid areas exposed to direct sunlight.

Application & Function

A) e.net (ethernet based protocol)
B) DALI

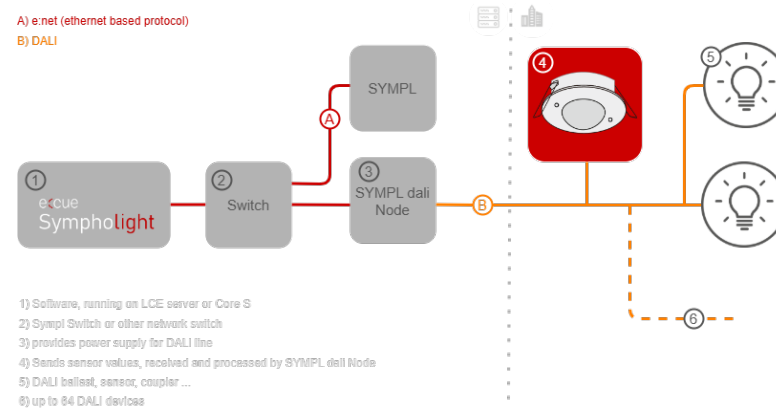

Integration in a system with DALI-2 compliant central control unit.

Instances

The DALI-2 Multi Sensor LS/MD supports 2 instances standardized according to DALI: occupancy sensor instance (303) for motion detection and light sensor instance (304) for illuminance measurement.

- Instance number 0: instance type is Occupancy sensor.
- Instance number 1: instance type is Light sensor.

Instances - General

Each instance can be configured individually. Some settings have the same functionality for all sensor instances and are therefore described in this section. Instance specific settings are explained for each individual instances in the following respective sections.

Enable / Disable

If instances are not required, they can be deactivated. In this case, event messages are not sent and the measured values are not updated. They can, however, still be queried via a "Query" command, and the DALI-2 configuration commands and queries are still supported.

Event Scheme

The event scheme determines which information is transferred with the event. This information is required to enable recognition and / filtering of events on the bus. The following 5 options are available:

- Instance addressing: instance type and instance number.
- Device Addressing: device address and instance type.
- Device / Instance Addressing: device address and instance number.
- Device Group addressing: device group and instance type.
- Instance Group Addressing: Instance group and instance type.

Instance group: Up to three instance groups can be assigned for each instance. Only the "Primary Group" is used for the event.

Instance type: The instance type defines which DALI-2 standard is valid for this instance. (The different instance types are specified in the DALI-2 standard.)

Instance number: Each instance in a device has a unique instance number.

Device group: The device can be assigned to up to 32 device groups (0...31). The lowest device group is used for the event.

Device address: a device address (or short address) (0..63) can be assigned to each device. With this the device can be clearly addressed. (Identical short addresses should be avoided.)

Event Priority

The event priority determines the order in which events are sent when they occur simultaneously on the bus.

Priority 2 = highest and 5 = lowest.

Dead Time

The dead time can be set for each instance. It determines the time that must pass before an event can be sent again. This also applies if the event information (measured value) changes. If no dead time is required, it can be deactivated.

Report Time

If the event information does not change, the event is sent cyclically with the report time. It determines the maximum time between a sent event and re-sending. The report time can be set for each instance and can be switched using the Repeat event.

Hysteresis

Not every change in value leads to an event being generated. The hysteresis can be used to set which percentage change is necessary to trigger a new transmission. Attention, the hysteresis band is not arranged symmetrically. The following applies:

Increasing value: The condition for an event is only fulfilled if the next value falls below the previous value minus the hysteresis or if the next value is greater than the previous value.

Decreasing value: The condition for an event is only fulfilled if the next value exceeds the previous value plus the hysteresis or the next value is smaller than the previous value.

Hysteresis Min

Hysteresis Min is the minimal hysteresis value that cannot be fallen below of.

Instance 0 – Occupancy Sensor

Instance 0 is an instance standardized by DALI-2 (62386-303), for sensors that detect motion. All settings are implemented according to the standard. The instance is DALI-2 certified.

The sensor switches between the following states:

- People in the room and movement (0xFF)
- People in the room and no movement (0xAA)
- Empty room (0x00)

If the sensor detects movement, it immediately changes to the state: “people in the room and movement”. This state is exited after 1 second at the earliest if no further movement is detected.

In this case it changes to the state “People in the room and no movement”. After the hold time has expired it changes to the state “Empty room”- Vacant.

Hold Time: The time that must pass before the state “people in the room and no movement” is changed to the state “empty room”. If movement is detected during this time the state is changed back to: “People in the room and movement”. (min. 1 second)

Query Input Value: The current sensor state can be queried using this DALI command. The following values are possible: 0x00, 0xAA,0xFF (see paragraph above for the possible states)

Event: The sensor status is transmitted by events. The following event information is available:

Event Name	Event Information	Description
No movement	00 0000 ---0b	No movement detected. Corresponding trigger is the 'No movement' trigger.
Movement	00 0000 ---1b	Movement detected. Corresponding trigger is the 'Movement' trigger.
Vacant	00 0000 -00-b	The area has become vacant. Corresponding trigger is the 'Vacant' trigger.
Still vacant	00 0000 -10-b	The area is still vacant. The event occurs at regular intervals as long as the vacant condition holds. Corresponding trigger is the 'Repeat' trigger.
Occupied	00 0000 -01-b	The area has become occupied. Corresponding trigger is the 'Occupied' trigger.
Still occupied	00 0000 -11-b	The area is still occupied. The event occurs at regular intervals as long as the occupied condition holds. Corresponding trigger is the 'Repeat' trigger.
Movement sensor	00 0000 1---b	The current event is triggered by a movement based sensor.
	1x xxxx xxxxb	Reserved.
	01 xxxx xxxxb	
	00 1xxx xxxxb	
	00 01xx xxxxb	
	00 001x xxxxb	
	00 0001 xxxxb	

For more details please refer to the standard IEC62386-303.

Event filter: The event filter defines for which status change an event is generated.

Filter arrangement:

Bit0: Occupied Event active

Bit1: Vacant Event active

Bit2: Still Vacant/Occupied Event active

Bit3: Movement Event active

Bit4: No Movement Event active

Bit5 ... Bit7: unused.

Report Time: report time can only be set if the event filter “Repeat” is activated and the events: “Still Vacant” and “Still Occupied” are enabled. The time between sending a “Still-Event” again is determined by the Report Time.

Configuring Instance 0 – Occupancy Sensor

1. Set filter (SET EVENT FILTER): 1 Byte, corresponding relationship of each BIT and default value are as follows:

Bit	Description	Value	Default
0	Occupied event enabled?	“1” = “Yes”	1
1	Vacant event enabled?	“1” = “Yes”	1
2	Repeat event enabled?	“1” = “Yes”	0
3	Movement event enabled?	“1” = “Yes”	0
4	No movement event enabled?	“1” = “Yes”	0
5	Reserved	0	0
6	Reserved	0	0
7	Reserved	0	0

This command value: 0x68

2. Set hold time (SET HOLD TIMER (DTR0))

1 Byte, (1---255), actual value: HOLD TIMER×10S

This command value: 0x21

3. Set report time (SET REPORT TIMER (DTR0))

1 Byte, (0---255), actual value: REPORT TIMER×1S

This command value: 0x22

4. Set dead time (SET DEADTIME TIMER (DTR0))

1 Byte, (0---255), actual value: DEADTIME TIMER×50MS

This command value: 0x23

5. Query instance resolution (QUERY RESOLUTION)

The resolution of occupancy sensor input value is 2,

This command value: 0x81

6. Query current input value of instance (QUERY INPUT VALUE)

Input values of occupancy sensor (4 values: 0, 0x55, 0xaa, 0xff)

This command value: 0x8c

Instance 1 – Light Sensor

Instance 1 is an instance standardized by DALI-2 (62386-304). All settings are implemented according to the standard. The instance is DALI-2 certified.

The current light value (Lux) is measured by the sensor and can either be queried using a “Query” command or can be automatically provided by the sensor using an event.

The measuring range is 0 ... 1000Lux. The resolution differs between queries and generated events. A query supports an event resolution of 10Lux (10Bit).

Hysteresis: For information on the hysteresis see section Instances -General: Hysteresis

Hysteresis Min: Set in lux. For general information on the hysteresis min see section Instances – General: Hysteresis Min

Event Filter: The light instance generates only one event with 10Bit resolution (0... 1000Lux, step size 10Lux). If the filter is deactivated, no events will be sent.

Event: The illuminance level is transmitted by event. The following event information is available:

Event Name	Event Information	Description
illuminance level report	illuminanceEvent	An illuminance level report, passing the actual illuminance level along.

For more details please refer to the standard IEC62386-304.

Configuring Instance 1 – Light Sensor

1. Set filter (SET EVENT FILTER): 1 Byte, only 1 BIT used, corresponding relationship and default value are as follows:

Bit	Description	Value	Default
0	Illuminance level event enabled?	“1” = “Yes”	1
1	Reserved	0	0
2	Reserved	0	0
3	Reserved	0	0
4	Reserved	0	0
5	Reserved	0	0
6	Reserved	0	0
7	Reserved	0	0

This command value: 0x68

2. Set report time (SET REPORT TIMER (DTR0))

1 Byte, (0---255), actual value: REPORT TIMER×1S

This command value: 0x30

3. Set dead time (SET DEADTIME TIMER (DTR0))

1 Byte, (0---255), actual value: DEADTIME TIMER×50MS

This command value: 0x32

4. Set hysteresis (SET HYSTERESIS (DTR0))

1 Byte, (0---25%), actual value: HYSTERESIS ×current illuminance value

This command value: 0x31

5. Set hysteresis min (SET HYSTERESIS MIN (DTR0))

1 Byte, (0---255)

This command value: 0x33

6. Query instance resolution (QUERY RESOLUTION)

The resolution of illuminance is 10,

This command value: 0x81

7. Query instance current value (QUERY INPUT VALUE)

Current value of illuminance (0-1000),

This command value: 0x8c

8. Query instance current latch value (QUERY INPUT VALUE LATCH)

This command value: 0x8d

Configuration with SYMPHOLIGHT

Events & Timer Configuration (in Setup tab)

Properties	
DALI Occupancy Sensor Input	
Hold Timer [s]	90
Report Timer [s]	20
Deadtime Timer [s]	1.5
Occupied Event	<input checked="" type="checkbox"/>
Vacant Event	<input checked="" type="checkbox"/>
Repeat Event	<input checked="" type="checkbox"/>
Movement Event	<input checked="" type="checkbox"/>
No Movement Event	<input checked="" type="checkbox"/>

Hold Timer: This means hold time, hold time is the time that must pass before the state “people in the room and no movement” is changed to the state “empty room”. If movement is detected during this time the state is changed back to: “People in the room and movement”.

Report Timer: This means report time, if the event information does not change, the event is sent cyclically with the report time. The report time can be set for each instance. It determines the maximum time between a sent event and re-sending.

Deadtime Timer: This means dead time, the dead time can be set for each instance. It determines the time that must pass before an event can be sent again. This also applies if

the event information (measured value) changes. If no dead time is required, it can be deactivated.

Brightness & Fade Time & Delay Time Configuration (in Automation tab - Workflow Designer)

Set brightness and fade time for the DALI luminaires on the line with the block “DALI Ballast Line”.

Set delay time for reacting control actions with the blocks “Single Delay” or “Multi Delay”. Take care that the recurrence of presence can be detected by the sensor’s properties (Hold Timer, etc.) before the Presence Duration elapses. The Presence Duration value needs to be larger.

Example:

Workflow Designer: Presence Duration = 120

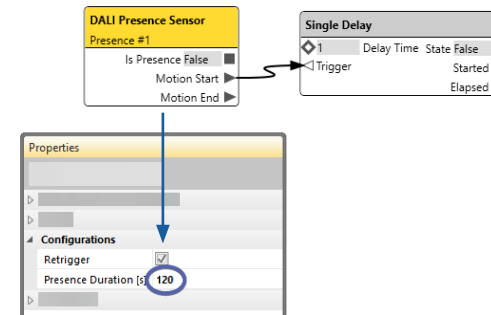

>

Setup tap: Hold Timer = 90

