

BEFORE MOUNTING, PLEASE READ THE USER MANUAL FOR CABLING AND CONNECTION DETAILS.

Mounting Guide

16PXL BOARD RGB 2.0

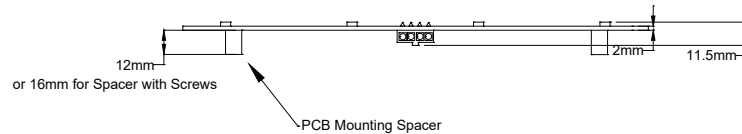
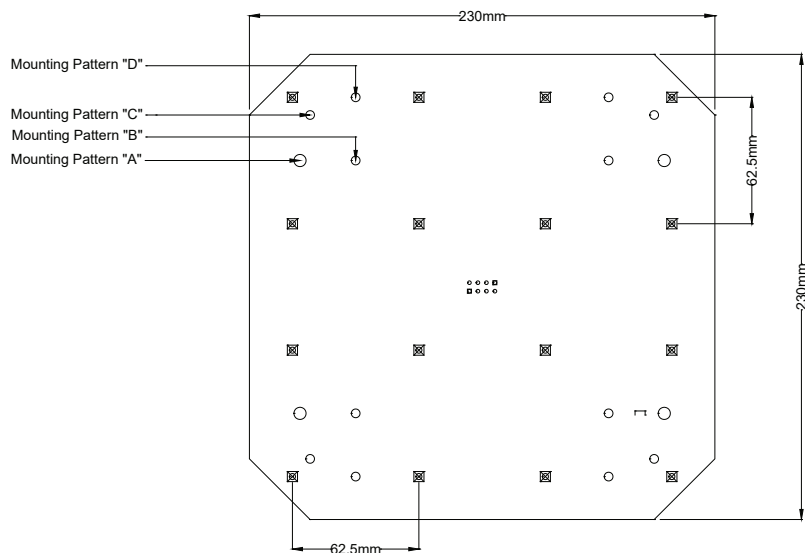

Mounting Accessories

Mounting kit Screw-Spacer (Ø 6mm)

Board holder, punch version (Ø 4.3mm)
Sheet metal

Board holder, drill version (Ø 4.3mm)
Wood

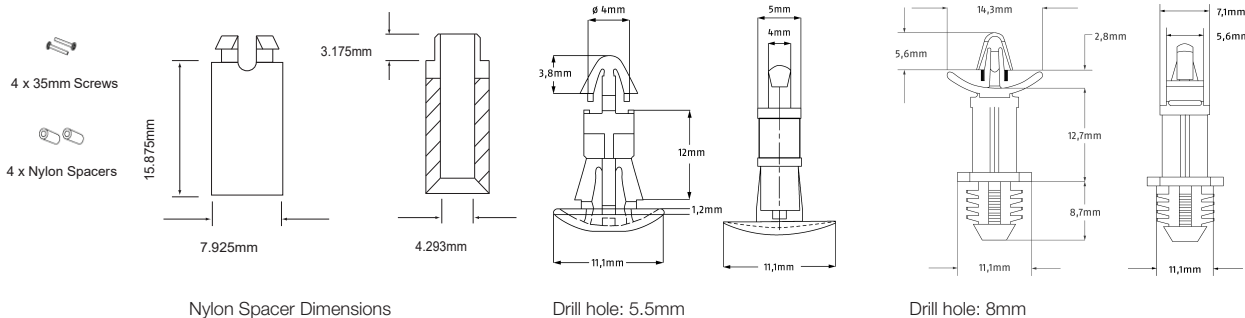

Nylon Spacer Dimensions

Drill hole: 5.5mm

Drill hole: 8mm

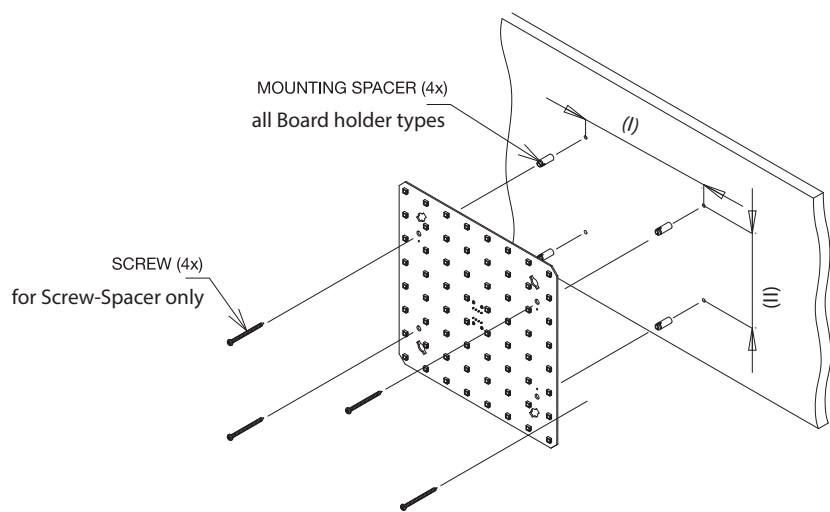

Mounting Pattern:

A : Ø 6mm; interspace 180mm (I) and 125mm (II);
for Screw-Spacer.

B : Ø 4.3mm; interspace 125mm (I) and 125mm (II);
for Board holder drill version and punch version.

C : Ø 4.3mm; interspace 170mm (I) and 170mm (II);
for Board holder drill version and punch version.

D : Ø 4.3mm; interspace 125mm (I) and 187.5mm (II);
for Board holder drill version and punch version.

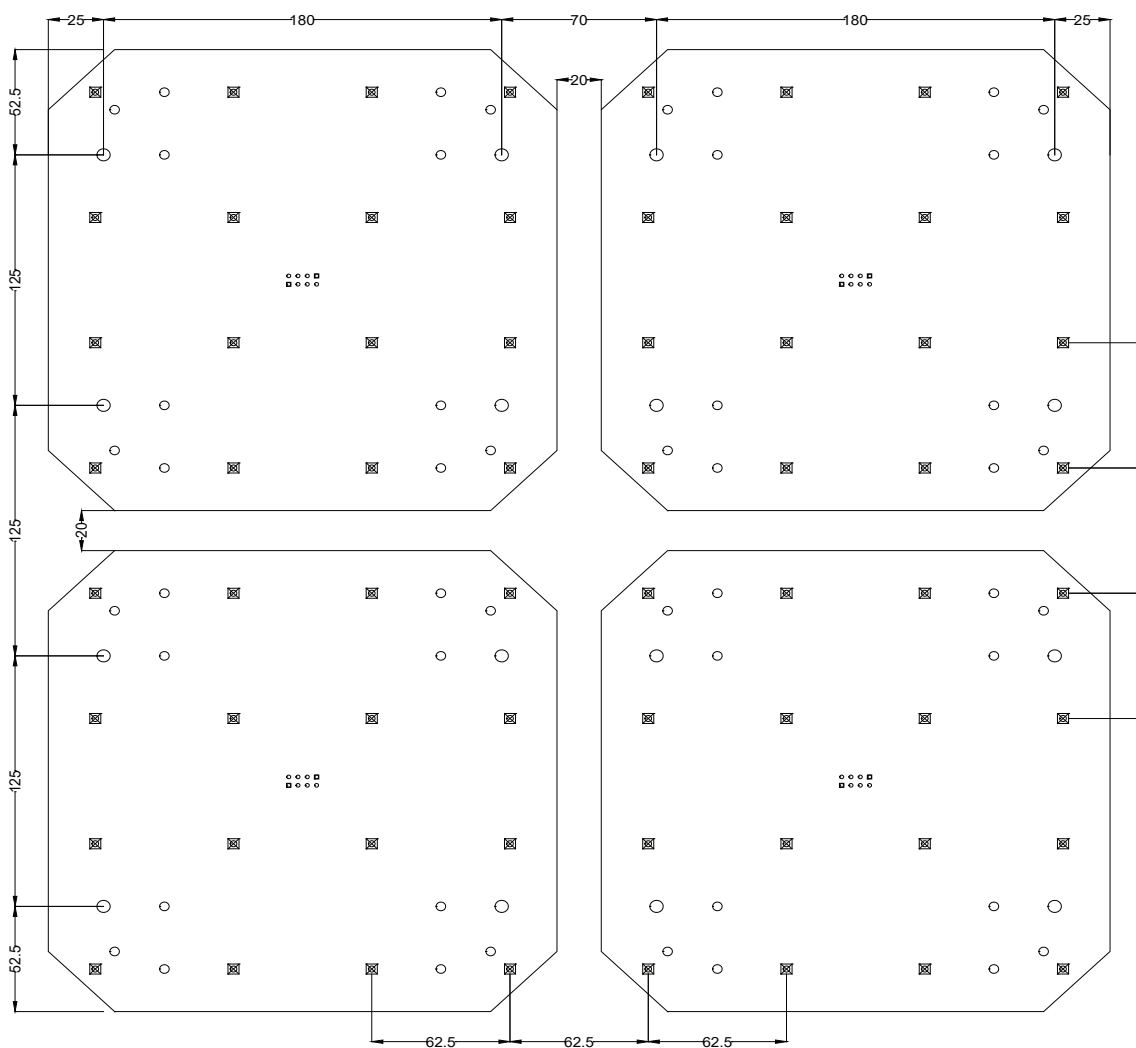

Orientation and Color Mixing

For left or right viewing angles, align the boards left to right or right to left.

For top or bottom viewing angles, align the boards top to bottom or bottom to top.

"Snake Mode"

"Snake Mode"

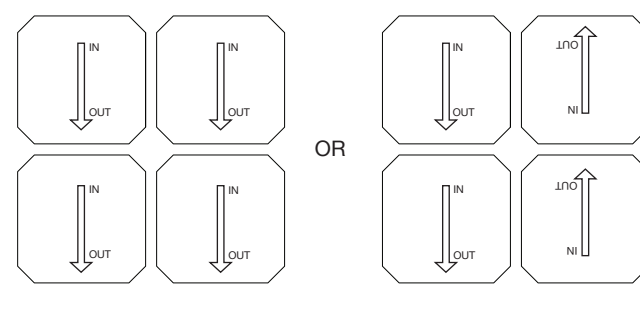
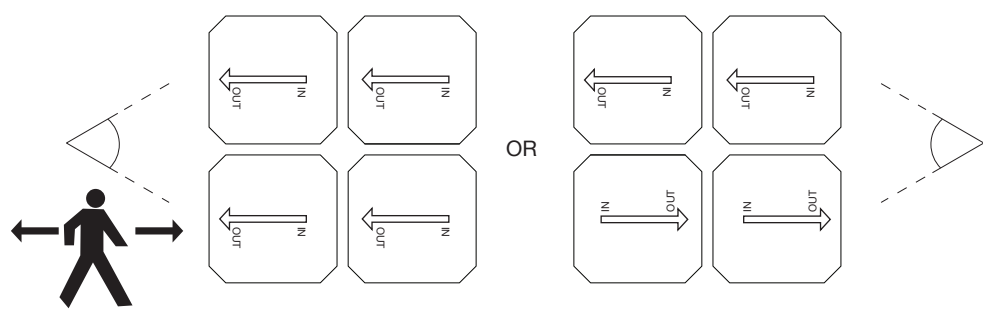

Main movement pattern

Main movement pattern

- For best color mixing results, ensure the boards have the same orientation and remain parallel to the main movement pattern of the viewer.
- If same orientation cannot be achieved, ensure the orientation of the boards that snake back are 180° to the previous row / column and consider the main movement pattern of the viewer.